

HY1838

IR Receiver Modules for Remote Control Systems

Description

The HY1838 is remote control receiver modules. Pin diode and receiver IC are assembled on one module. Small-sized, light-weight, and low current consumption modules have been achieved by using resin mold. The demodulated output signal can directly be decoded by a microprocessor. The main benefit is the reliable function even in disturbed ambient and the protection against uncontrolled output pulses.

Features

- ◆ Supply Voltage Range: 2.7V to 5.5 V
- ◆ TTL and CMOS compatibility
- ◆ Photo detector and preamplifier in one package.
- ◆ Internal filter for PCM frequency
- ◆ Output active low
- ◆ Enhanced Immunity against all kinds of disturbance light
- ◆ No occurrence of disturbance pulses at output pin with in nominal conditions.
- ◆ Short settling time after power On.
- ◆ Meet RoHS

Dimensions

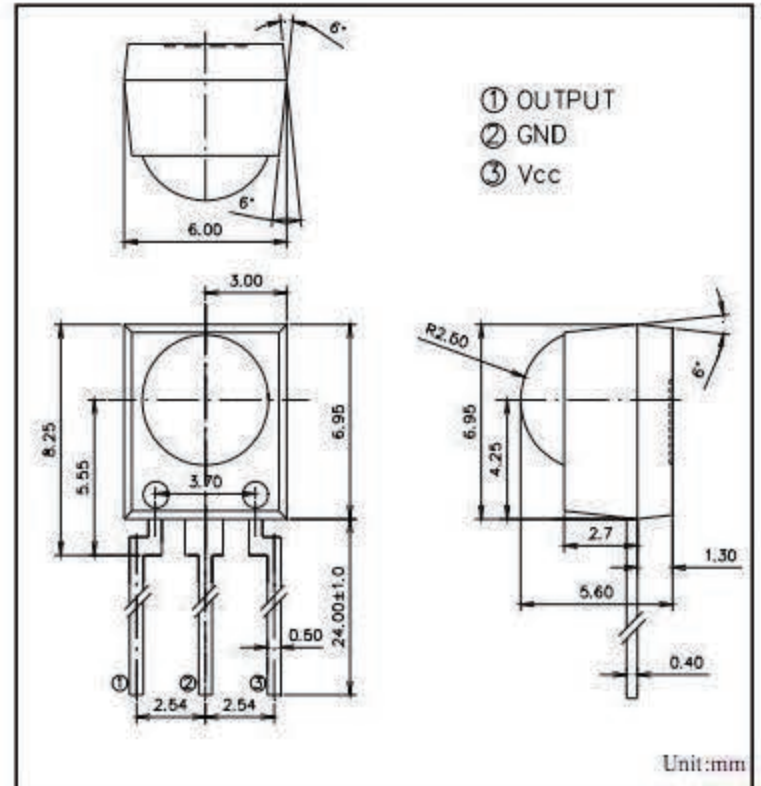

Applications

- ◆ Audio video applications
- ◆ Home appliances
- ◆ Toy applications
- ◆ Remote control equipment

Application Circuit

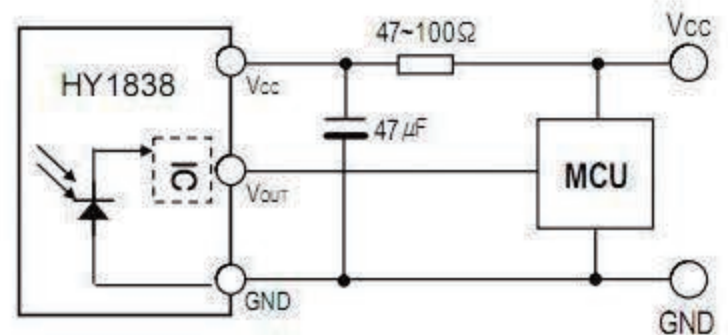
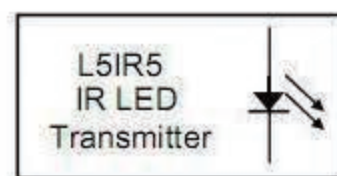

R-C filter recommended to suppress power supply disturbances.
R-C filter should be connected closely between Vcc pin and GND pin.

Block Diagram

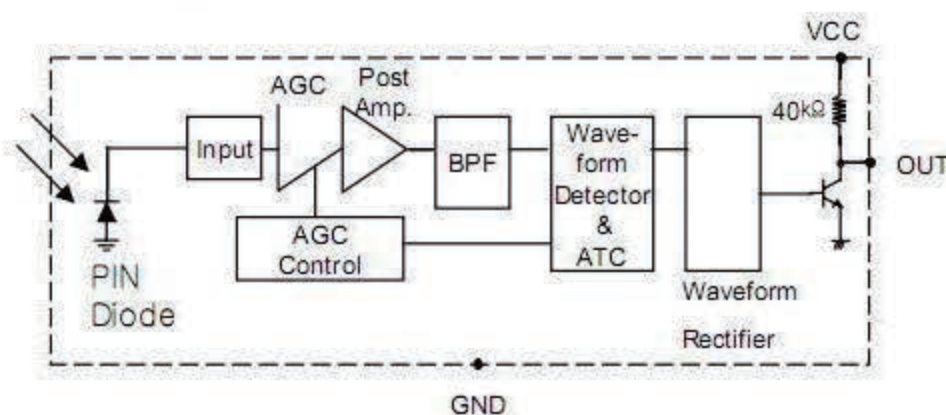

HY1838

Recommended Operating Conditions

(Ta = 25°C)

Parameter	Symbol	Min.	Typ.	Max.	Unit	Conditions
Operating Voltage	Vcc	2.7	5.0	5.5	V	
Input Frequency	fin	30	37.9	60	kHz	
Operating Temperature	Top	-20	25	80	°C	

Absolute Maximum Ratings

(Ta = 25°C)

Parameter	Symbol	Min.	Max.	Unit	Conditions
Supply Voltage	Vcc	0	6.0	V	
Output Voltage	Vout	0	6.0	V	
Output Current	Iout	0	2.5	mA	
Storage Temperature	Tst	-20	80	°C	
Soldering Temperature	Tsd	260°C±5°C		°C	Max 5 sec

Electro-optical Characteristics

Specifications hold over the Recommended Operating Conditions, unless otherwise noted herein.

All values are at 25f and Vcc=3.0V/5.0V

(Ta = 25°C)

Parameter	Symbol	Min.	Typ.	Max.	Unit	Conditions
Supply Current	Icc	--	0.9	1.5	mA	Iin=0 O , Vcc=3V
			1.0	1.5	mA	Iin=0 O , Vcc=5V
Max. Voltage gain	Av	75	80	85	dB	fin=37.9kHz, Vin=30mV p-p
BPF Bandwidth	fbw	3.5	6.0	8.5	kHz	-3dB Bandwidth Vin=30mV p-p
Output pulse width	tpw1	500	-	800	µs	fin=37.9kHz, burst wave Vin=500mV p-p note*1
	tpw2	500	-	800	µs	fin=37.9kHz, burst wave Vin= 50mVp-p note*1
Low level output voltage	VOL	-	0.2	0.4	V	Isink=2.0mA
High level output voltage	VOH	2.7	3.0	-	V	Vcc=3V
		4.7	5.0	-	V	Vcc=5V

HY1838

[Fig. 1] Data Signal diagram

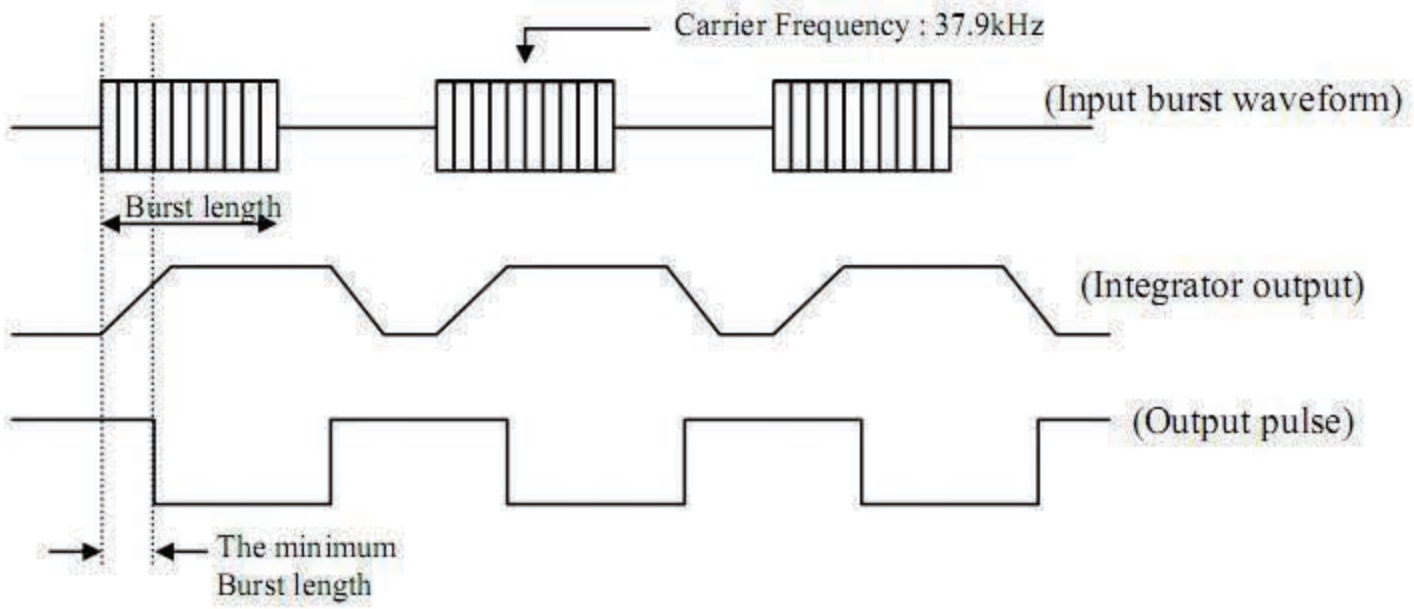

[Fig.2] Transmitter

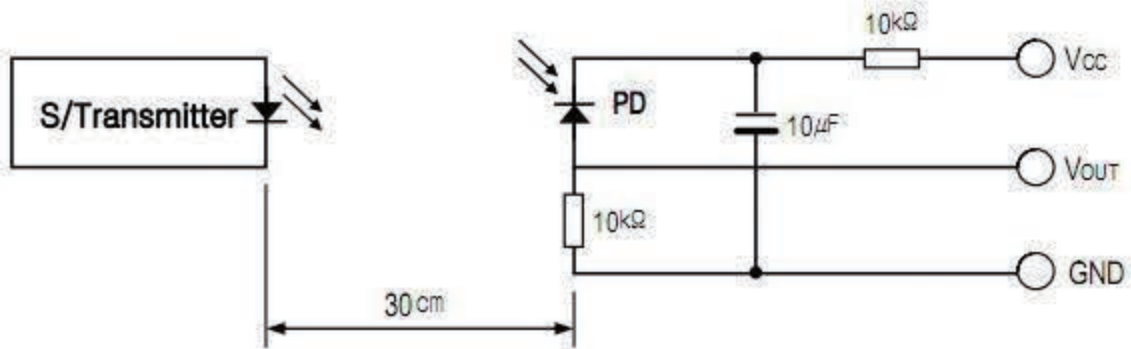

[Fig.3] Test condition of arrival distance

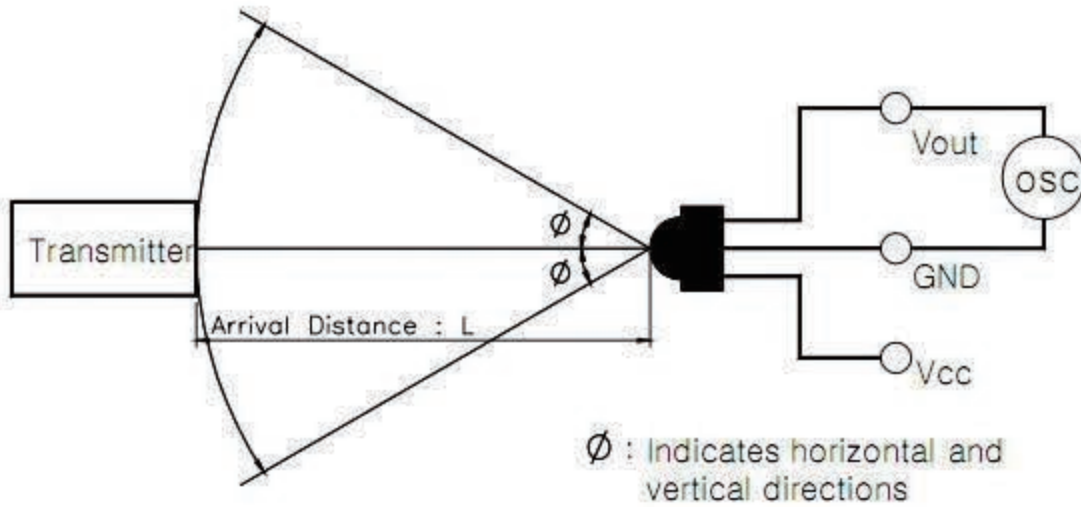

[Measurement condition for arrival distance]

Ambient light source : Detecting surface illumination shall be irradiate 200 ± 50 Lux under ordinary white fluorescence lamp without high frequency lighting

HY1838

Electrical/Optical Characteristics

[Fig.4] Supply Current vs. Voltage

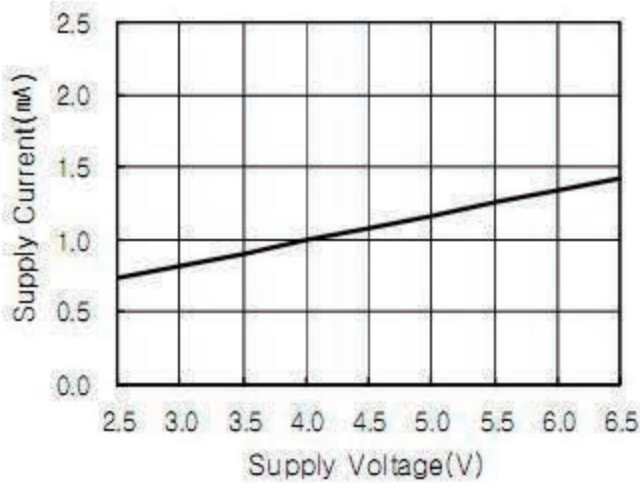

[Fig.5] Sensitivity vs. Supply Voltage

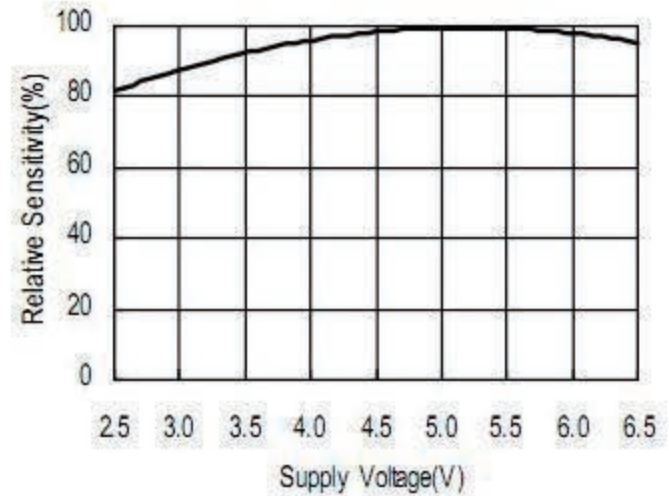

[Fig.6] Output Pulse Width vs. Distance

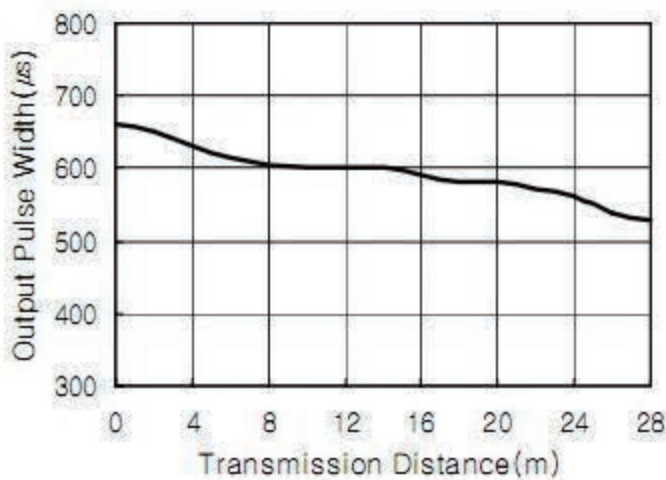

[Fig.7] Directivity (Horizontal)

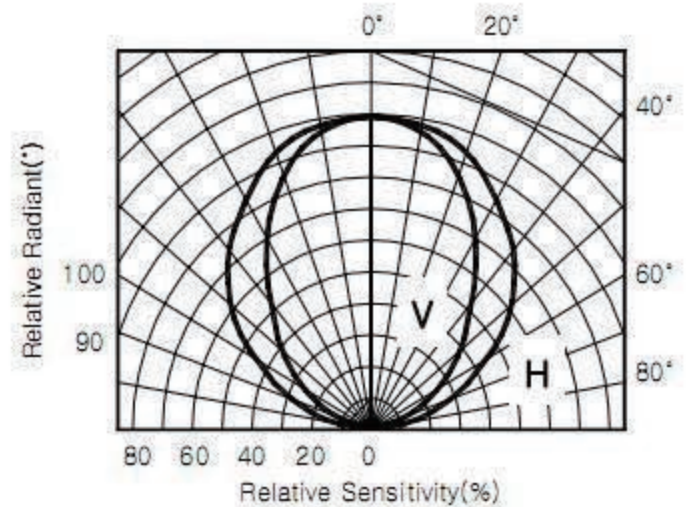

[Fig.8] BPF Fc Curve

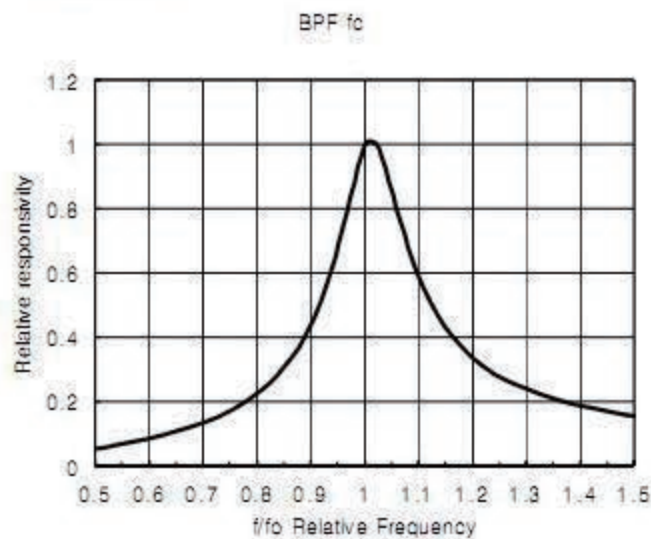

ESD Test Results

Parameter	Conditions	Specification	Results
Machine Model	C=200pF, R=0Ω	Min ±200V	>±200V
Human Body Model	C=100pF, R=1.5kΩ	Min ±2000V	>±2000V
Charged Device Model	R=100MΩ, 1Ω	Min ±800V	>±800V